

MAG Cascade Magnet Systems

Unit 6B, Aseman Tower, Khageh Abdollah Ansari St, Shariati Ave, Tehran-IRAN Tel/Fax: (+9821) 2285 7680-1 & 2286 6085-6

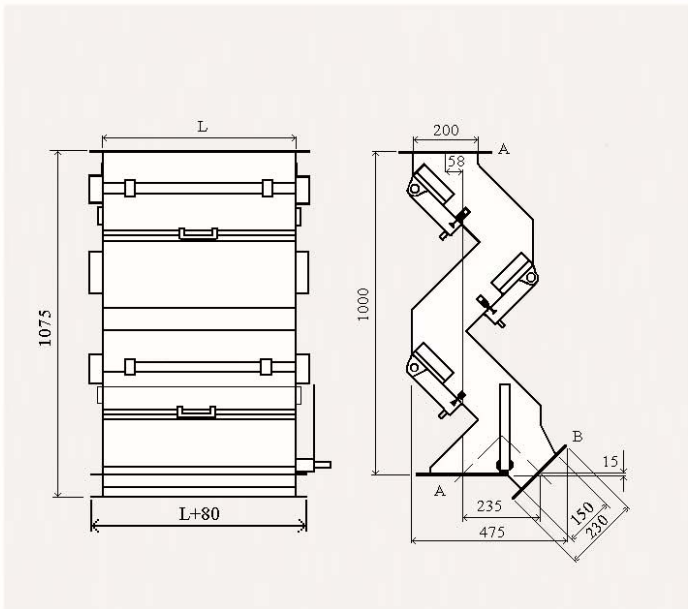

MAG 40.070

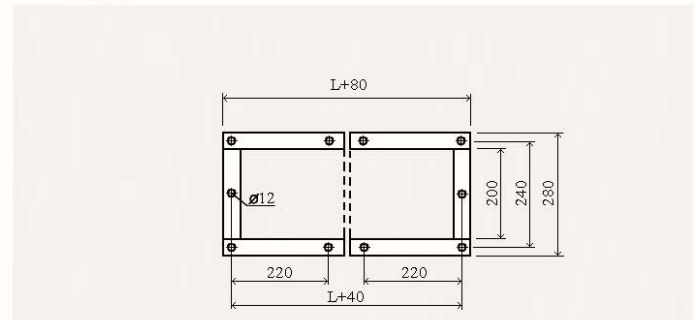

Manually-operated cascade magnet system with valve box.

Art.no.	L mm	capacity(t/hr)			weight (kg)
		grain	powder	scrap	
MAG 40.070	200	7-15	5-10	3-10	125
MAG 40.071	400	15-40	10-30	7-20	198
MAG 40.072	600	45-70	35-50	25-40	275
MAG 40.073	800	90-100	70-80	50-60	353
MAG 40.074	1000	140	100	80	431
MAG 40.075	1200	175	125	100	509

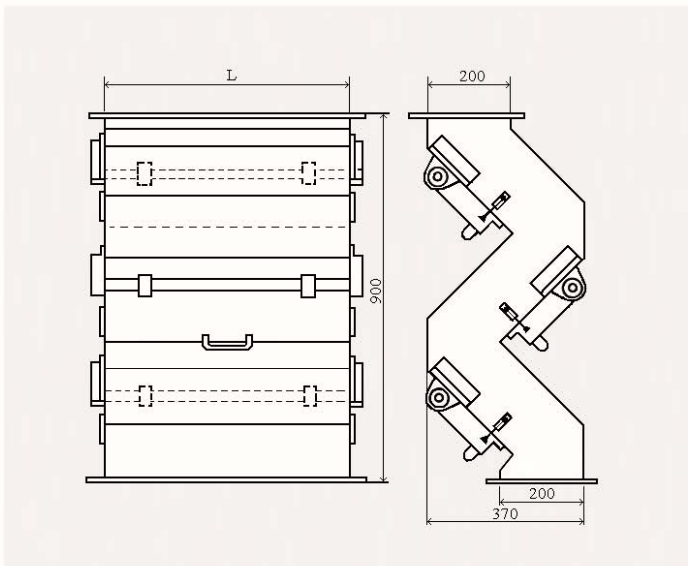

MAG 40.048

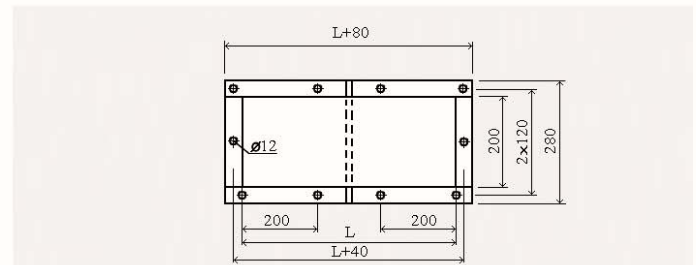

Manually-operated cascade magnet system without valve box.

Art.no.	L mm	capacity(t/hr)			weight (kg)
		grain	powder	scrap	
MAG 40.048	200	7-15	5-10	3-10	112
MAG 40.049	400	15-40	10-30	7-20	185
MAG 40.050	600	45-70	35-50	25-40	262
MAG 40.051	800	90-100	70-80	50-60	340
MAG 40.052	1000	140	100	80	418
MAG 40.053	1200	175	125	100	496

All dimensions in mm